

LS Motor Mount Bracket Installation Instructions

Brackets install on engine with the notch up and facing forward

Place bolts at front of slots. This will place the back of the LS engine in the same location as the Small Block Chevy or LT1. There is a 10mm (~3/8") adjustment for frame-frame differences. Placing bolts at rear of slot gives you a slight engine setback.

For 4WD applications where the original transmission and driveline is used, only locate the bolts in the forward end of the slot for correct fit.

FRONT
of
VEHICLE

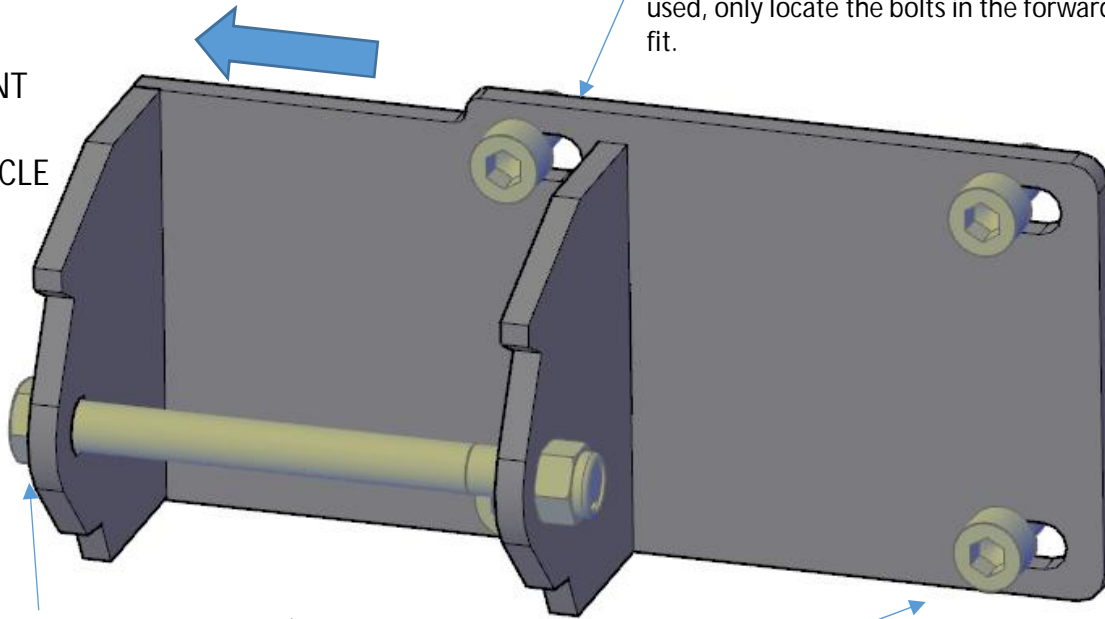

Torque Supplied 7/16
Fasteners to 52ft-#

Torque Supplied M10
Fasteners to 36 ft-#

Kit Contents

- 1 – Left bracket
- 1 – Right bracket*
- 8 – M10 x 1.5mm SHCS Bolts
- 2- 7/16-14 Bolts
- 2 – 7/16-14 Nylock nuts

* Right side bracket is shorter
for 94-96 B/D Body Kits

